

## Dynamometer – Model 326



- Capacities: 20N to 5kN
- Measuring uncertainty:  $\leq \pm 0,1\%$  of nominal value
- Measuring frequency: 1kHz
- 32bit RISC  $\mu$ Processor

The dynamometers of the model series 326 contain a high-resolution force sensor as well as processor-controlled electronic unit with most modern software. The main areas of application for these devices are quality assurance, incoming goods inspection, production and research and development.

Particularly operating forces as well as stability of components will be measured (springs, tracers, switches, levers, fasteners, etc.). The devices of model series 326 are used cross-sectorally e.g. in food industry, cosmetics, automotive, medical technology, precision mechanics or aerospace.

Model 326	
Measuring uncertainty	$\leq \pm 0,1\%$ of nominal value
Processor	32bit RISC $\mu$ Processor, 128kB Flash
A/D converter	16bit
Measuring frequency	1000Hz
Display	+ 5-digit + decimal point + backlit, 2,8" LCD display with 128x64 pixel
Indicator resolution	$\pm 20.000$ digits
Power supply	+ 4 customary AA Ni-Mh accumulators + USB charging device + also usable with standard batteries
Operating time	+ $\geq 10$ h without recharging + continuous indication of actual state of charge
Dimensions (HxWxD)	(170 x 75 x 35) mm
Weight	725 g to 850 g, depending on capacity
Housing	Die-cast aluminum housing RAL7035 with recessed grips and 2 M6 mounting holes, both on each front side and on the backside, for flexible installation in load frames

# Dynamometer – Model 326

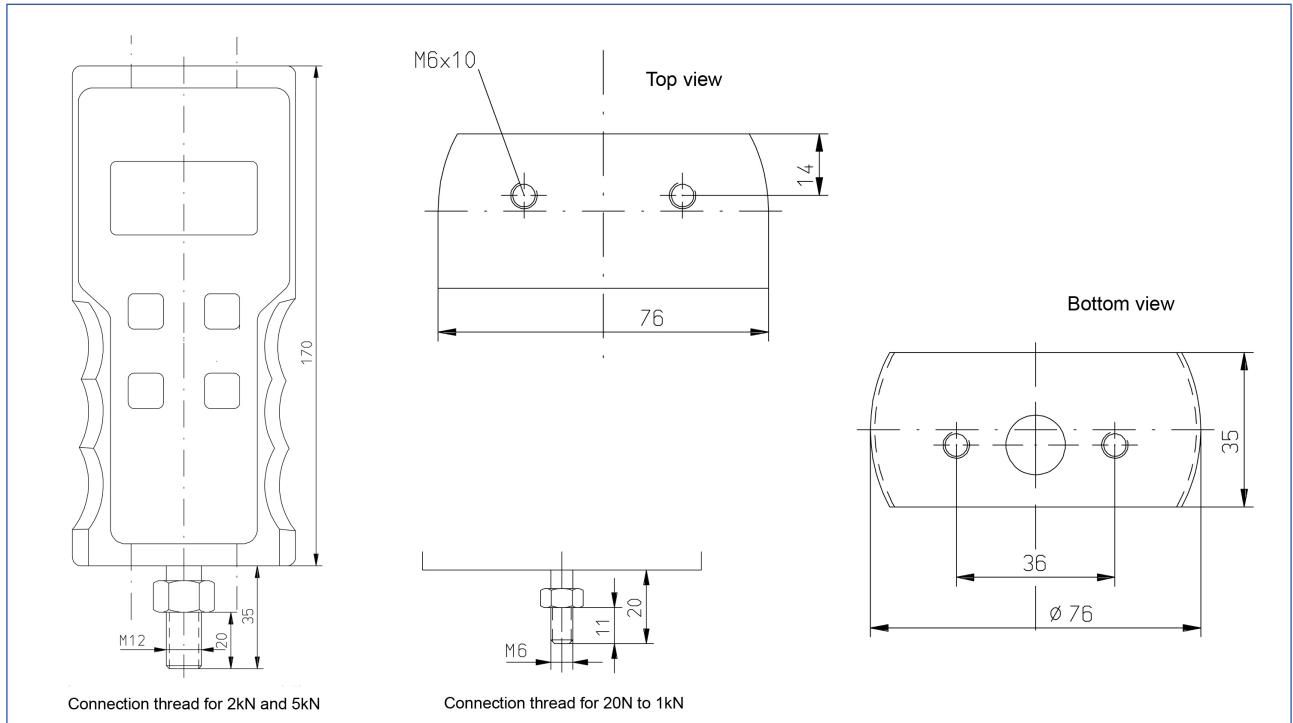

Model 326 - Scope of delivery	
Dynamometer with Transportation case	
+ User manual	
+ USB charging device + USB cable	

for 20N to 1kN: (below, left)	
+ Tension hook + Connecting piece (WxL: 19 x 52mm)	
+ Elongation (L: 47mm)	
+ round compression piece (L: 25mm $\varnothing$ 27mm)	
for 2kN and 5kN: (below, centre)	
+ Compression piece (L: 32mm $\varnothing$ 18mm)	
+ Elongation (L: 68mm)	
+ Optional (surcharge): Eye bolt (WxL: 54 x 53mm)	

