

## Electrical Force Transducers – Model 307



- Capacities: 20N to 500N (I)
- And 1kN to 25kN (II)
- For compression and tension
- Stainless steel / Aluminum
- Highest accuracy
- Also as calibration version
- Reference transducer up to 2kN
- Sensitivity: 2mV/V
- TEDS module (inside sensor) <sup>1)</sup>
- With threaded connector

The electrical force transducers of the model series 307 are suitable for compressive and tensile measurements. The sensors that are made of stainless steel or aluminum (depending on capacity) are available in two sizes. They are suitable for static applications as well as for slightly dynamic applications while a TEDS module is already integrated inside the devices. On demand you receive the model 307 in version Cl. 00 which achieves class 00 according to ISO 376 and is used for calibration purposes.

Model 307				
>> Technical data according to VDI / VDE directive 2638				
	Symbol	Unit	Standard	Cl. 00
Zero signal when removed	$S_0$	mV/V	0,02	0,02
Rated characteristic value	$C_{nom}$	mV/V	2	2
Relative error of characteristic value	$d_c$	% ( $\leq \pm$ )	0,25	0,1
Relative linearity error	$d_{lin}$	% ( $\leq \pm$ )	0,03	0,01
Relative repeatability error in unchanged mounting position	$b_{rg}$	% ( $\leq \pm$ )	0,02	0,02
Combined error	$F_{comb}$	% ( $\leq \pm$ )	0,05	0,0115
Reference temperature	$T_{ref}$	°C	21	21
Rated temperature range	$B_{T, nom}$	°C	-10...+40	-10...+40
Operating temperature range	$B_{T, G}$	°C	-15...+60	-15...+60
Storage temperature range	$B_{T, S}$	°C	-20...+70	-20...+70
Relative creep after 30 min	$K_{0,5}$	% ( $\leq \pm$ )	0,03	0,012
Relative creep after 8 h	$K_8$	% ( $\leq \pm$ )	0,009	0,007
Temperature effect on characteristic value per 10K	$TK_C$	% ( $\leq \pm$ )	0,01	0,0024
Temperature effect on zero signal per 10K	$TK_0$	% ( $\leq \pm$ )	0,04	0,0045
Input resistance	$R_e$	$\Omega$	400 $\pm$ 20	400 $\pm$ 20
Output resistance	$R_a$	$\Omega$	350 $\pm$ 2	350 $\pm$ 2
Insulation resistance	$R_{is}$	G $\Omega$	> 5	> 5
Max. excitation voltage	$U$	V	10	10
Rated range of excitation voltage	$B_{U, nom}$	V	5...10	5...10
Limit force	$F_L$	%	$\leq 150$	$\leq 150$
Breaking force	$F_B$	%	$\geq 300$	$\geq 300$
Max. permissible dynamic load <sup>3)</sup>	$L_{dy}$	%	$\leq 50$	$\leq 50$
Degree of protection acc. to DIN 60529			IP60/65	IP60/65
<sup>1)</sup> TEDS = Transducer Electronic Data Sheet acc. to IEEE 1451.4		<sup>3)</sup> Oscillation amplitude acc. to DIN 50100		
<sup>2)</sup> The class 00 is suitable as reference force transducer acc. to ISO 376 and also suitable for calibrations of materials testing machines acc. to ISO 7500-1.				

# Electrical Force Transducers – Model 307

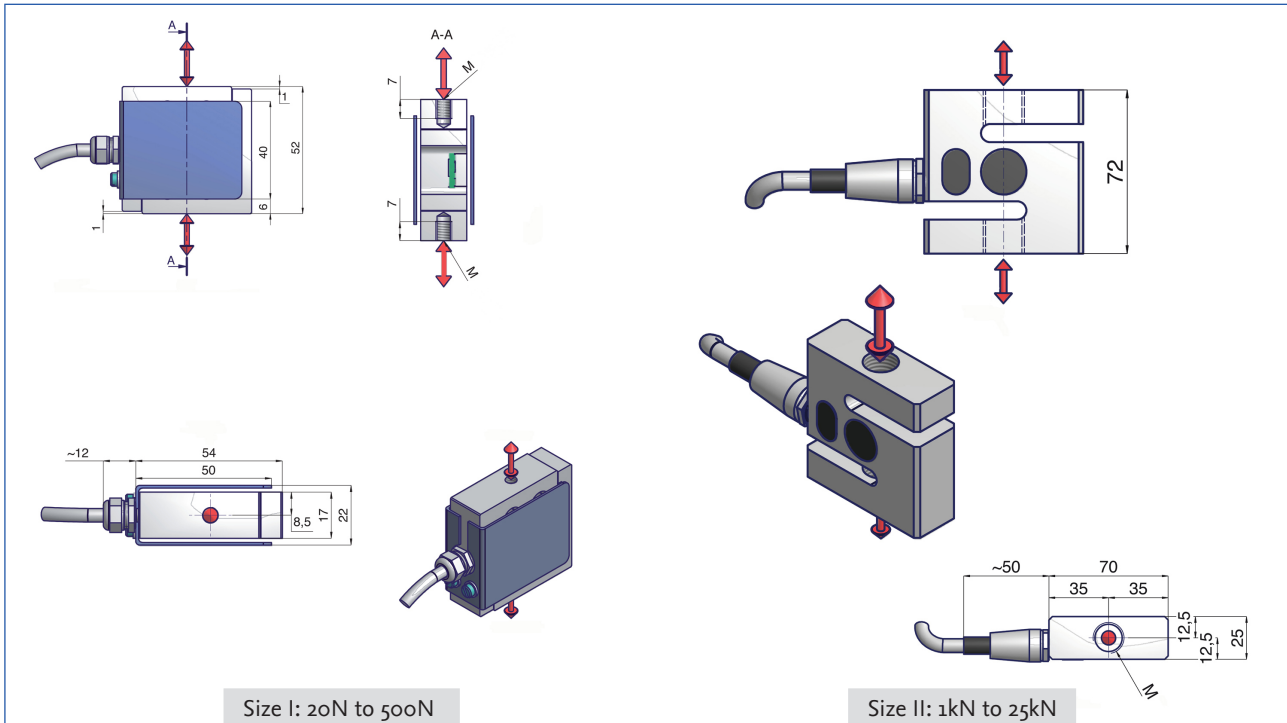

Dimensions in mm			
Model 307	Size I	Size II	
	20N	1kN	20kN
	50N	2kN	25kN
	100N	5kN	
	200N	10kN	
	500N		
M	M6 x1	M12 x 1,75	M16 x 2

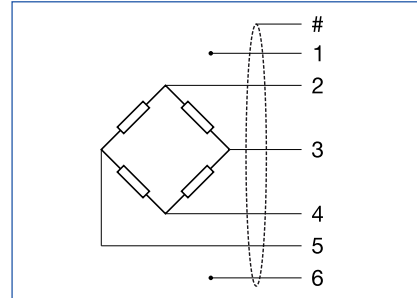

**Advice for tensile force measurements:**  
 For force transmission please pay attention to an installation that is free of lateral forces, if necessary use rotating intermediate parts or joint heads with shackles.  
 For safety reasons you should use arresting cables, straps or chains when other mechanical protection is not existing.

Connection Drawing		
1	white	TEDS Data
2	red	Excitation +
3	yellow	Output +
4	blue	Excitation -
5	green	Output -
6	black	TEDS GND
#		Shield

Classification according to ISO 376							
Relative deviation of the force gauge %							Expanded uncertainty of applied calibration force (level of confidence 95 %) %
Class	of reproducibility b	of repeatability b'	of interpolation fc	of zero fo	of reversability v	of creep c	
00	0,05	0,025	± 0,025	± 0,012	0,07	0,025	± 0,01