

**UPDATED
PRODUCT**

Small profile and ultra-light weight, these units are appropriate for testing small and delicate samples yet rugged enough for daily use on standard specimens. Ideal for wire specimens, sheet materials, and standard ASTM or ISO specimen geometries, and excellent for low and high cycle fatigue testing.

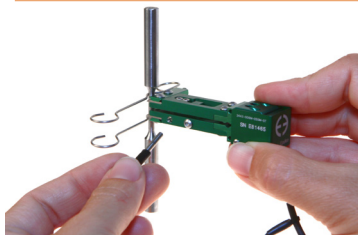

Model 3442 low-profile extensometer with gauge length pin

Weighing as little as 8 grams, these miniature extensometers are designed to have very low operating force with minimal specimen influence. All use an improved version of Epsilon's dual flexure design which makes them very rugged for their size. With a module height of 15.2 mm (0.6 inches), they will fit in the limited space between grips that is typical with small test samples.

Gauge lengths can be as short as 3 mm or as long as 50 mm. A newly designed gage setting pin and assembly allows the gauge length to be set accurately and repeatably to ASTM and ISO requirements for all gauge lengths. Reengineered quick attach wire forms provide simple and secure specimen attachment. Wire forms for round and flat specimens are included, as well as flat, 3-point, and vee knife edges. The wire forms may be removed to enable mounting using elastic bands or springs. A tethering attachment point provides fall protection and enables counterbalancing of the extensometer's weight when testing delicate specimens.

Model 3442 extensometers are strain gaged devices, making them compatible with any electronics designed for strain gaged transducers. Most often they are connected to a test machine controller and Epsilon will equip the extensometer with a compatible connector wired to plug directly into the controller. For systems lacking the required electronics, Epsilon can provide a variety of solutions for signal conditioning and connection to data acquisition systems, chart recorders, or other equipment.

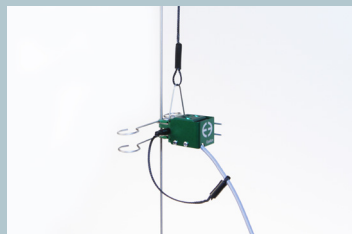

Model 3442 with 6.0 mm gauge length, ±1.0 mm (±16.7% strain) measuring range, and suspension tether



Model 3442 with 6.0 mm gauge length and +5.0 mm/-1.0 mm (+83%/-17% strain) measuring range

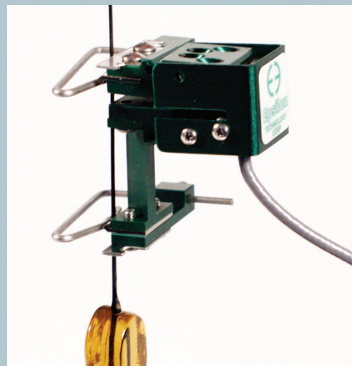

Model 3442 with 1 inch gauge length testing carbon fiber tow

Extensometers for Composites Compression Testing

Models 3542 and 3442 extensometers can be furnished to clip directly onto composites compression fixtures, such as for ASTM D695. These use specially made quick attach kit wire forms for the test fixture. Consult the factory for specifics.

Also see the Model 3542 extensometer.



Rubber band and spring attachment options included with Models 3442 and 3542

Features

- **May be left on through specimen failure.**
- Gauge length pin helps set gauge length accurately for all gauge length configurations.
- All models can measure in both tension and compression and can be used for cyclic testing.
- Mechanical overtravel stops in both directions.
- Rugged, dual flexure design for strength and improved performance. Much stronger than single flexure designs, this also allows cyclic testing at higher frequencies.
- Standard units meet ASTM class B-1 requirements for accuracy. A test certificate is included. ISO 9513 class 0,5 test certificates are available upon request.
- Gauge length adapter kits enable configuration of multiple gauge lengths with one extensometer.
- Replaceable arms and spacers for ease of repair.
- High and low temperature options extend operation from as low as -265 °C (-450 °F) to +200 °C (400 °F).
- Full bridge, 350 ohm strain gaged design for compatibility with nearly any test system.
- Includes high quality foam lined case.

SPECIFICATIONS

- Excitation:** 5 to 10 VDC recommended, 12 VDC or VAC max.
Output: 2 to 4 mV/V nominal, depending on model
Linearity: ≤0.15% of full scale measuring range
Temperature Range: Standard (-ST) is -40 °C to +100 °C (-40 °F to 210 °F)
Cable: Integral, ultra-flexible cable, 2.5 m (8 ft) standard
Standard Quick Attach Kit: Fits round samples up to 13 mm (0.5 inch) diameter and flats up to 13 mm thick by 15 mm wide (0.5 inch by 0.6 inch); attach to larger specimens using rubber bands or springs (included)
Operating Force: 10 to 20 g typical

OPTIONS

- Adapter kits to change gauge lengths
- Connectors to interface to nearly any brand test equipment
- Special coatings and stainless steel knife edges available for biomedical tests.
- Shunt calibration module (see page 120)
- Specialty knife edges (see page 100)

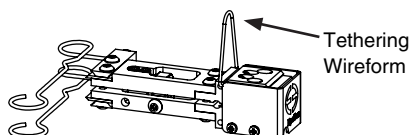

ORDERING INFORMATION

Model 3442 Available Versions: ANY combination of gauge length, measuring range and temperature range listed above is available, except as noted. The measuring range should not exceed the gauge length. Other configurations may be available with special order; please contact Epsilon to discuss your requirements.

Gauge Length		Measuring Range	
U.S.A.		U.S.A.	
-0025	0.250 in	-005T	±0.050"
-0030	0.300 in	-010T	+0.100"/-0.050"
-0050	0.500 in	-025T ²	+0.250"/-0.050"
-0064	0.640 in	-050T ²	+0.500"/-0.050"
-0100	1.000 in	METRIC	
-0200	2.000 in	-005M	±0.5 mm
METRIC		-010M	±1.0 mm
-003M ¹	3.0 mm	-020M	+2.0 mm/-1.0 mm
-004M ¹	4.0 mm	-025M	+2.5 mm/-1.0 mm
-005M ¹	5.0 mm	-050M ²	+5.0 mm/-1.0 mm
-006M	6.0 mm	-100M ²	+10.0 mm/-1.0 mm
-008M	8.0 mm	-125M ²	+12.5 mm/-1.0 mm
-010M	10.0 mm		
-012M	12.0 mm		
-0125M	12.5 mm		
-020M	20.0 mm		
-025M	25.0 mm		
-050M	50.0 mm		

Model Number 3442- _____ - _____ - _____

Temperature Range	
-LT	-265 °C to 100 °C (-450 °F to 210 °F)
-ST	-40 °C to 100 °C (-40 °F to 210 °F)
-HT1	-40 °C to 150 °C (-40 °F to 300 °F)
-HT2	-40 °C to 200 °C (-40 °F to 400 °F)
-LHT	-265 °C to 200 °C (-450 °F to 400 °F)

¹ Available in -005M, -010M, and -020M measuring ranges only; meets accuracy requirements for ASTM E83 B-2 class.
² Extended compression range available up to 50% of tensile range for GL>10 mm

Example: 3442-008M-010M-ST: 8 mm gauge length, ±1.0 mm measuring range, standard temperature range (-40 °C to 100 °C)

Visit our website at www.epsilontech.com
 Contact us for your special testing requirements.

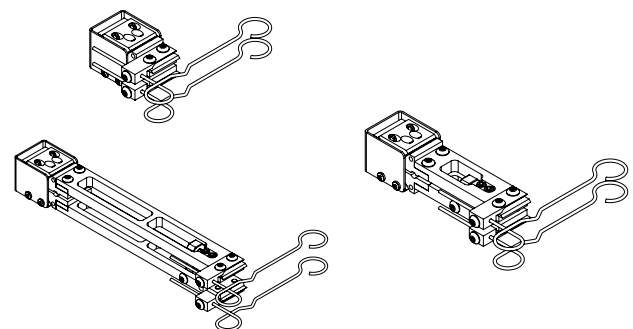

MODEL 3442 EXAMPLES